

# The HC1 miniBOOSTER



**HC1 versions:** 9 different intensification factors

**P<sub>IN</sub>:** 20 – 200 bar (inlet pressure)

**P<sub>H</sub>:** 800 bar maximum (outlet pressure)

**P<sub>RETURN</sub>:** As low as possible (Return pressure to tank)

**Intensification ratios:**  $P_H = (P_{IN} - P_{RETURN}) \cdot i$  (Intensification)

**Mounting:** Inline tube

**Accessories:** Pilot operated dump valve available

**A model** = no dump valve

**B model** = with dump valve

**G model** = direct proportionally controlled

## Description

The HC1 is the most compact miniBOOSTER unit weighing only 0.7 kg. It is ideal for use in applications where it is desirable to mount the unit on or in a tool, power pack, or other device.

The HC1 raises supplied pressure to a higher outlet pressure and automatically compensates for consumption of oil to maintain the high pressure. Adjustment of the outlet pressure is carried out by varying the supplied pressure.

Intensification factor i	Max. outlet flow l/ min	Max. inlet flow l/ min
1.2	0.5	8.0
1.5	0.5	8.0
2.0	0.5	8.0
2.8	0.5	8.0
3.3	0.5	8.0
4.0	0.4	8.0
4.8	0.4	8.0
6.2	0.3	8.0
7.5	0.3	8.0

## Dimensions

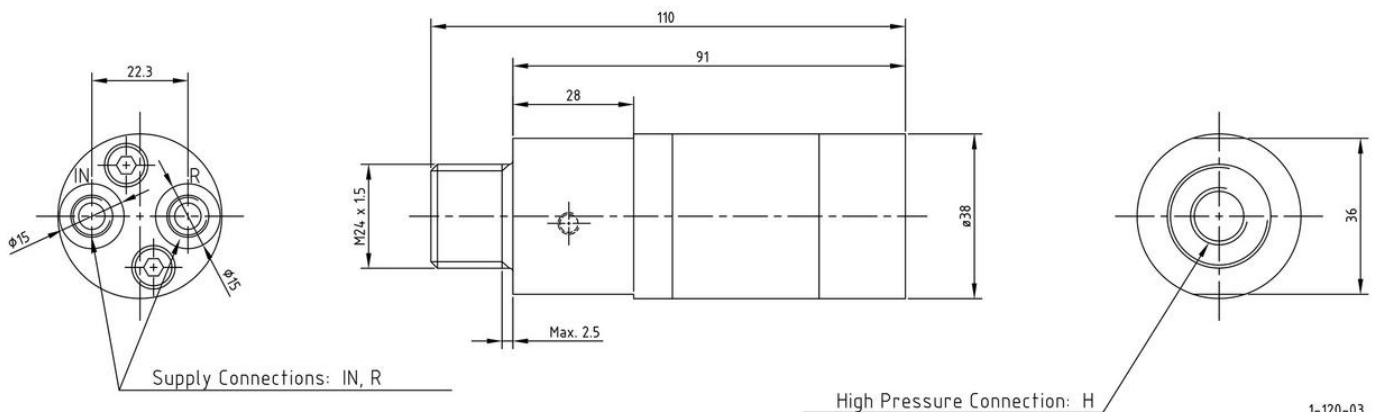

## Functions

The basic operation is illustrated in the function diagram. Oil is fed through the directional valve CV to the IN port, flowing freely through the check valves KV1, KV2 and DV to the high pressure side H. In this condition maximum flow through the booster is achieved giving a fast forward function.

When pump pressure is reached on the high pressure side H, valves KV1, KV2 and DV will close. The end pressure will be achieved by the oscillating pump unit OP. The unit will automatically stall when end pressure on high pressure side H is reached. If there is a pressure drop on the high pressure side due to consumption or leakage, the OP valve will automatically operate to maintain the end pressure.

## Function Diagram

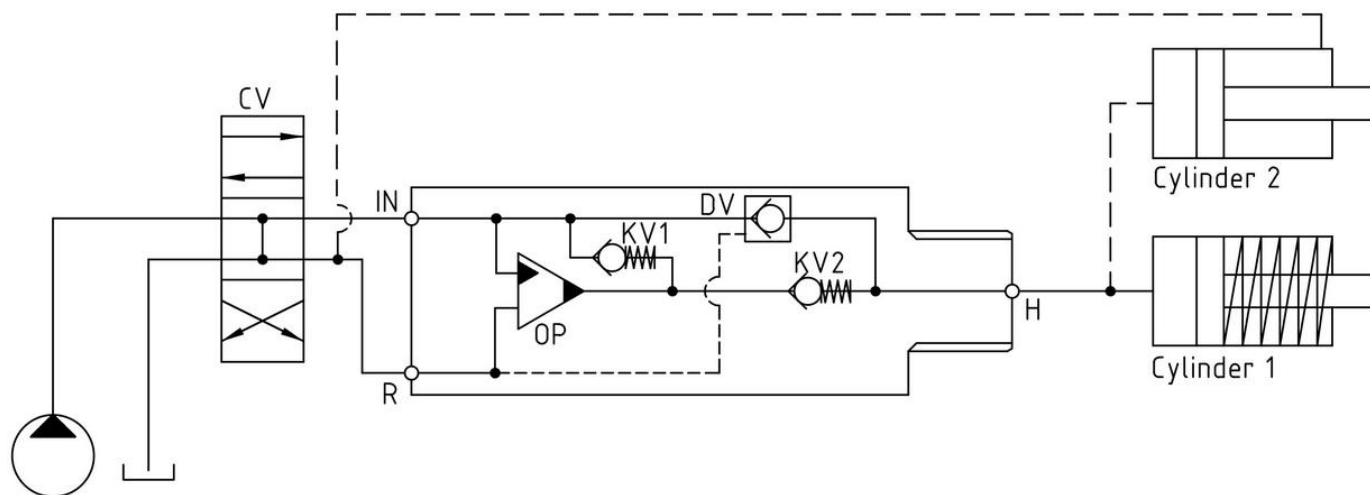

1-105-01

## Connection types

Connection	IN / R	H
1	1/8" BSP	1/4" BSP
2	3/8-24 UNF	9/16-18 UNF

## Max. tightening torque BSP

	IN / R	H
	1/8" BSP	1/4" BSP
with steel washer	2.0 da/ Nm	4.0 da/ Nm
with aluminium washer	1.0 da/ Nm	-
with cutting edge	2.0 da/ Nm	4.0 da/ Nm

## Max. tightening torque UNF

	IN / R	H
	3/8-24" UNF	9/16-18" UNF
with o- ring	1.5 da/ Nm	3.5 da/ Nm

## Fluids and materials

Please see General Specifications.

## Ordering a HC1

Ordering example of a HC1 with  $i = 3.3$ , DV incorporated and BSP connections: HC1 - 3.3 - B - 1

<i>Model</i>	<i>Intensification, i</i>	<i>Dump Valve</i>	<i>Connections</i>
HC1	your selection...	your selection...	your selection...
	see flow rate table	A = (no) / A model	1
		B = (yes) / B model	2
		G = (proportional) / G model	