

## The HC3- F miniBOOSTER



**HC3 - F versions:** 11 different intensification factors

**P<sub>IN</sub>:** 20 – 200 bar (inlet pressure)

**P<sub>H</sub>:** 500 bar maximum (outlet pressure)

**P<sub>RETURN</sub>:** As low as possible (Return pressure to tank)

**Intensification ratios:**  $P_H = (P_{IN} - P_{RETURN}) \cdot i$  (Intensification)

**Mounting:** Manifold system miniBOOSTER pattern

**Accessories:** Pilot operated dump valve available

**A model** = no dump valve

**B model** = with dump valve

**G model** = direct proportionally controlled

### Description

The HC3 - F is an up- right standing variant of the HC3 with a 10 micron filter and 2 orifices incorporated. It has all ports in one end and the hole pattern is a miniBOOSTER design. It is a compact unit weighing only 4.3 kg.

The HC3 has the pilot operated dump valve incorporated as a standard feature. Maximum outlet pressure is 500 bar in standard versions. Adjustments of the outlet pressure is carried out by varying the supplied pressure.

### Flow Rates

Intensification factor i	Max. outlet flow l/ min	Max. inlet flow l/ min
1.2	1.2	8.0
1.5	1.0	8.0
2.0	2.0	12.0
2.8	2.2	13.0
3.2	2.5	15.0
4.0	2.0	14.0
5.0	1.6	14.0
6.6	1.3	13.0
9.0	0.9	13.0
13.0	0.6	12.0
20.0	0.3	12.0

## Dimensions

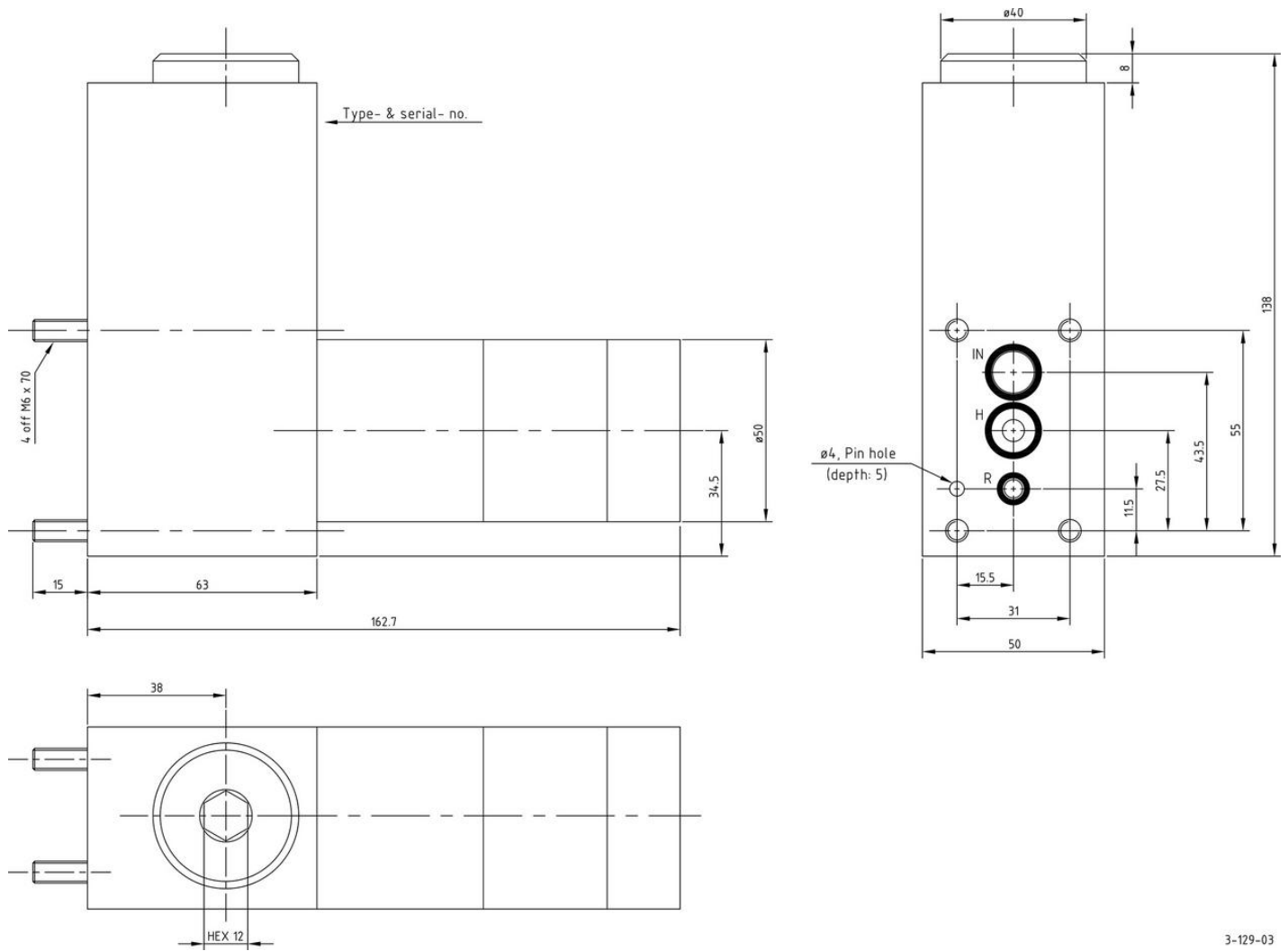

3-129-03

## Functions

The basic operation is illustrated in the function diagram. The oil is fed through the connecting plate and the filter to the IN port of the HC3 flowing freely through check valves KV1, KV2 and DV to the high- pressure side H.

From the high- pressure side H oil is fed to port A on the connecting plate. In this condition maximum flow through the booster is achieved giving a fast forward function. When pump pressure is reached on the high- pressure side H, valves KV1, KV2 and DV will close. The end pressure will be achieved by the oscillating pump unit OP. The unit will automatically stall when end pressure on high- pressure side is reached. If there is a pressure drop on the high- pressure side due to consumption or leakage, the OP valve will automatically operate to maintain the end pressure.

## Function Diagram

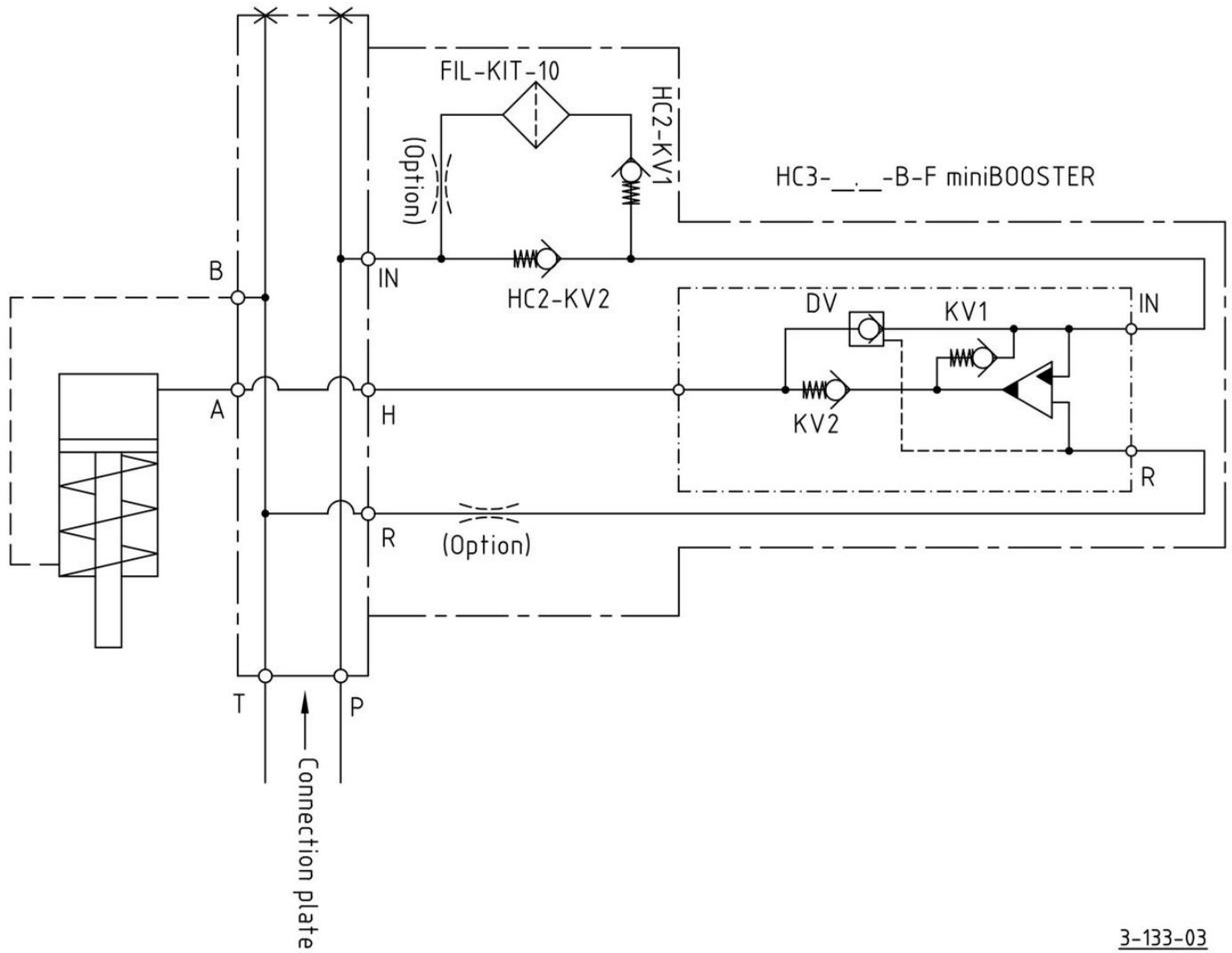

3-133-03

## Fluids and materials

Please see General Specifications

## Ordering a HC3- F

Ordering example of a HC3 - F with  $i = 4.0$ , DV incorporated: HC3 - 4.0 - B - F

Model	Intensification, $i$	Dump Valve	Model
HC3	your selection...	your selection...	F
	see flow rate table	A = (no) / A model	
		B = (yes) / B model	
		G = (proportional) / G model	